

TURNILS MACHINE DIVISION

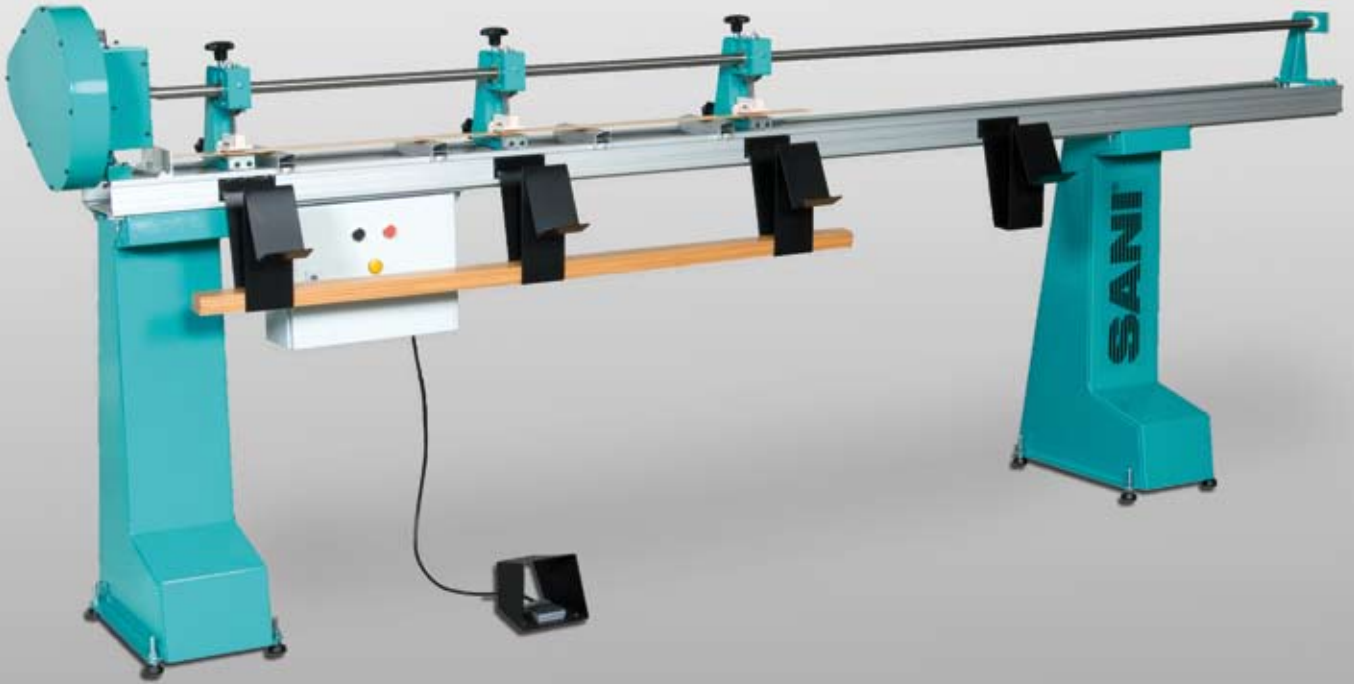

The machine in this picture may be fitted with additional equipment.

SANI 216W

Wood slat machine – with manual feeding for easy hole punching

The 216W is a wood slat punching machine, which is easy to operate and maintain. Slat production is straightforward. The operator quickly sets the length and the punching stations using the integrated measurement device or according to head rail. All holes are punched simultaneously by pressing the foot pedal.

Adaptable for most wooden or composite slat materials between 25 and 63,5 mm, the machine can be easily switched between different slat widths. Slat lengths between 120 and 3000 mm can be accommodated with a standard setup.

The 216W comes as part of a comprehensive range of proven Turnils machinery, production equipment and support services to help you increase the range, capacity and efficiency of your VB production.

SANI 216W

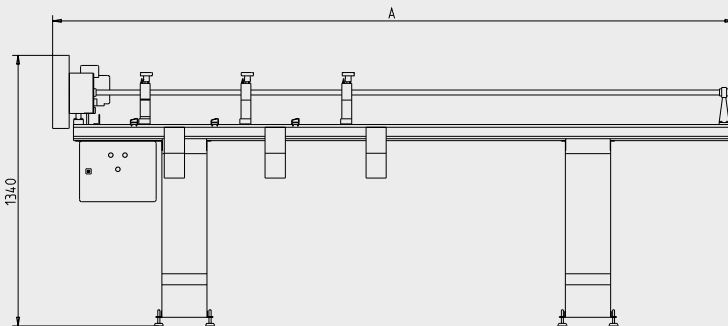

Slat length (mm)	Machine dimension (mm)
3000	4100
4000	5100
5000	6100

216W features

- Wood slat hole punching machine
- Manual slat feeding into the punching stations
- All holes are punched simultaneously
- Can be built to suit different slat widths between 25-63,5 mm (1"-2,5")
- Quick and easy change between slat widths
- Adaptable for most wooden and composite materials
- Easy setting of punching stations
- Handles slat lengths from 120 to 3000 mm
- Flexible first hole position, minimum distance from slat edge to first hole 30 mm
- Easy to install, operate and maintain
- Support services i.e. technical support, spare parts, installation and training

Additional equipment

- Guide hole equipment

Technical data

- Current 3x 230/400V (50/60HZ)